

INSTALLED - (2) 1045A-HP SCREWS

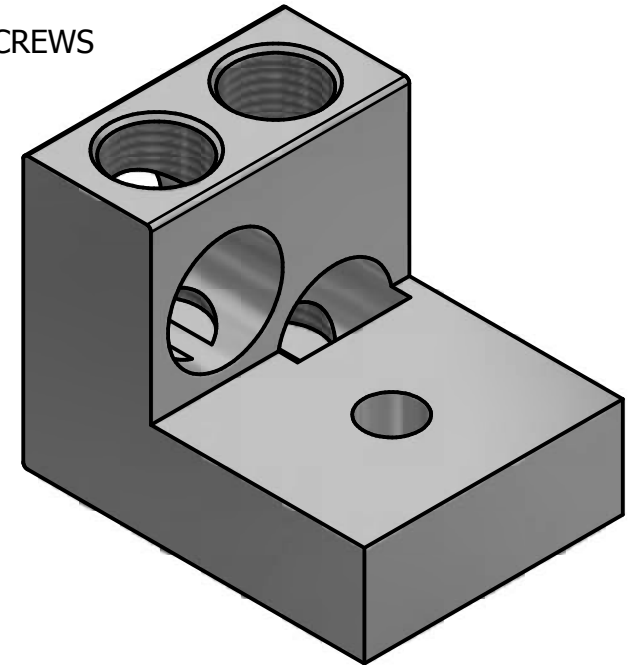
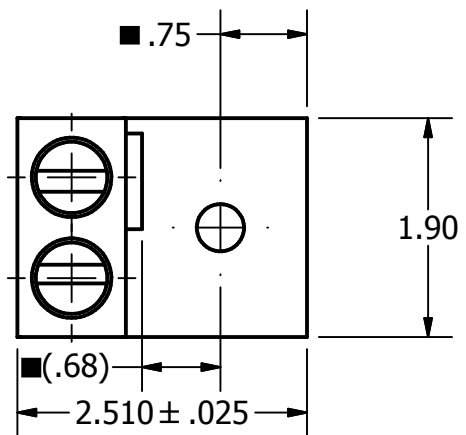

Cat. No. 2SL500 Style No. 3

■ Drill, Enlarge, or Modify Mounting Holes

- 1) Increase hole(s) dia. to 5/8 bolt.
- 2) Move location of mounting hole(s)
- 3) If buying blank lug, put custom hole(s) in.

IHI UL/CSA Installation Guide to Drill or Enlarge Mounting Holes:

<https://lugsdirect.com/PDF%20Documents/IHI-MTG-HOLE-FIELD-MODS-UL&CSA-CERTIFICATIONS.pdf>

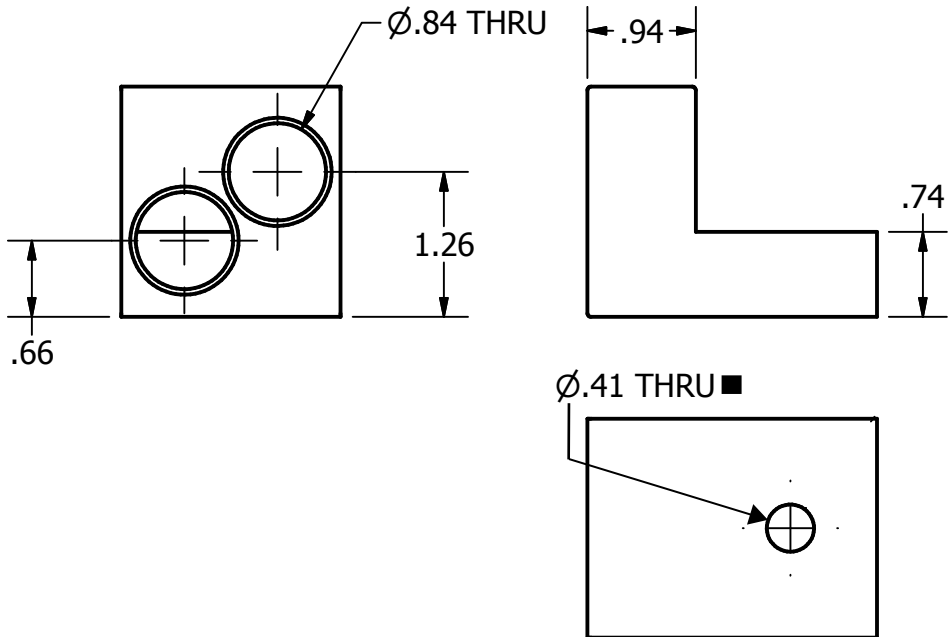

IHI Connectors
International Hydraulics Inc.
ihiconnectors.com™



Pressure Terminal Connectors
NRTL Cat. No.
2SL500

500kcmil-4/0 AL9CU 90°

Wire Size Copper (solid to semi-rigid stranded and metric mm ² , #)	Wire Size FLEX Copper	Wire Size aluminum	Torque (all drive means)
(2) 500-4/0	N/A	(2) 500-4/0	300

All Torque in in-lbs. For N-M divide by 8.85.

(##) mm² sizes within AWG & kcmil ranges are included.

THIS DRAWING AND DESIGN ARE THE PROPERTY OF INTERNATIONAL HYDRAULICS, INC., CLEVELAND, OHIO, AND MAY NOT BE DUPLICATED, USED FOR THE BASIS OF DESIGN OR MANUFACTURE WITHOUT THE WRITTEN PERMISSION OF INTERNATIONAL HYDRAULICS, INC., CLEVELAND, OHIO.

IHI CONNECTORS INTERNATIONAL HYDRAULICS, INC.
TITLE: **2LS500-41-75**
COMPACT WIDTH LUG (SALES)

GENERAL TOLERANCES ±.015 (±0,39)		SIZE: A	DRAWN BY: cridley	DWG NO.:	REV:
MATERIAL: 6061-T6	DATE: 6-12-2019	2LS500-41-75		0	
FINISH: TIN PLATED					

NOT FOR USE WHERE FAILURE CREATES A HAZARD TO HUMAN HEALTH OR SAFETY.
ALL PRODUCTS ARE SUBJECT TO THIS FULL DISCLAIMER: <http://www.ihiconnectors.com/disclaimer.html>

FOR FURTHER INFORMATION ON THE PROPER USE OF THIS PRODUCT IN SPECIFIC APPLICATIONS SEE
<http://www.ihiconnectors.com/GuideToFlexFlexibleFineStrandedWireCableMechanicalLugsFAQ.html>

<http://www.ihiconnectors.com/Technical-Data-Installation.htm>