

**Ring Lug Mount (RLM)
Screw Tightening Torques**

All torques in inch-lbs. (Divide by 8.85 for N-m)

When Using	THT Mounts		SMT Mount	Lug body Wrench Size 3/8" (9.5mm)
	Min	Max		
-RLM B4A-PCB	35	37-80**	##	

(**) Use of an open ended wrench on the lug to counter the applied torque is recommended in case the soldered mount to PCB is compromised by excessive torque applied through to the soldered PCB joint.

(##) All SMT mounts require that the torque applied should be established by purchaser using data on the strength of the SMT joint in the worst case.

In addition, use of an open ended wrench on the SMT mounted lug to counter the applied torque is recommended in case the soldered mount to PCB is compromised by excessive torque applied through to the soldered PCB joint. See image right.

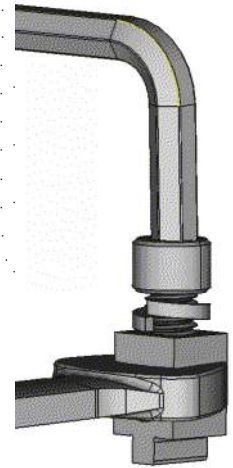
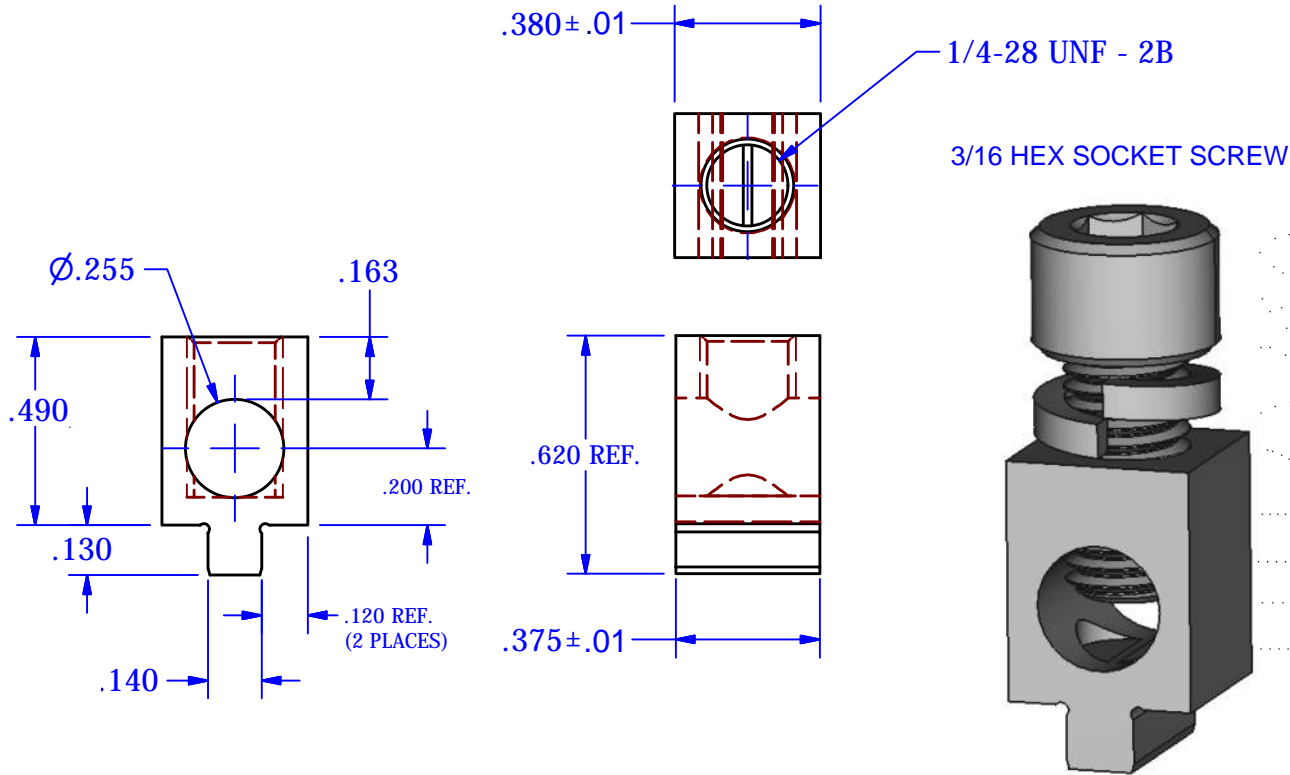

NOTES:

1. FINISH: TIN PLATE FOR SOLDERING
2. PART IS NOT UL/CSA LISTED/CERTIFIED BUT IS CAPABLE OF PASSING UL486 IF PROPERLY IMPLEMENTED ON PCB
3. FOR .06"-.10" BOARD THICKNESS
4. USE ROUTED SLOT IN PCB FOR .140 FOOT, ALL FINAL PCB SPECS BASED ON BUYER TESTING AND APPROVAL
5. STANDARD PART HAS 1 HEX SCREW & 1 WASHER KITTED SMALL WIRES
8. SMT MOUNTED VERSIONS MOUNTED AT 90° ON SIDE

NOT FOR USE WHERE FAILURE CREATES A HAZARD TO HUMAN HEALTH OR SAFETY. ALL PRODUCTS ARE SUBJECT TO THIS FULL DISCLAIMER: <http://www.ihconnectors.com/disclaimer.html>

FOR FURTHER INFORMATION ON THE PROPER USE OF THIS PRODUCT IN SPECIFIC APPLICATIONS SEE <http://www.ihconnectors.com/GuideToFlexFlexibleFineStrandedWireCableMechanicalLugsFAQ.html>
<http://www.ihconnectors.com/Precautions-when-using-SMT.pdf>
http://www.ihconnectors.com/FAQ_SMT_SMD_High_CurrentPCB_Terminal_LugsSolderCreep.htm
http://www.ihconnectors.com/High_Amp_Wide_Trace_PCB_Wire_Connection.html
<http://www.ihconnectors.com/Technical-Data-Installation.htm>
[http://www.ihconnectors.com/NOTESonPCBFootPrintLayouts\(SMT-SMD-Mode\).pdf](http://www.ihconnectors.com/NOTESonPCBFootPrintLayouts(SMT-SMD-Mode).pdf)

REV	DESCRIPTION			DATE	BY
1	INITIAL RELEASE			4/27/2016	DJH
<small>THIS DRAWING AND DESIGN ARE THE PROPERTY OF INTERNATIONAL HYDRAULICS, INC., CLEVELAND, OHIO, AND MAY NOT BE DUPLICATED, USED FOR THE BASIS OF DESIGN OR MANUFACTURE WITHOUT THE WRITTEN PERMISSION OF INTERNATIONAL HYDRAULICS, INC., CLEVELAND, OHIO.</small>					
GENERAL TOLERANCES ± .013		INTERNATIONAL HYDRAULICS, INC. TITLE: B4A-PCB-2RLM-KIT 85A RING LUG MOUNT (SALES)			
MATERIAL: 6061 T6 (XB4A)	SIZE: A	DRAWN BY: TDS	DWG NO.:	REV:	
FINISH: SEE NOTE	DATE: 2/10/16	THIS IS A CAD DRAWING, DO NOT MANUALLY REVISE			