

COPYRIGHT (PER LATEST REVISION DATE) OF INTERNATIONAL HYDRAULICS, INC. (IHI®). ALL RIGHTS RESERVED. THIS COMPLETE ENGINEERING DRAWING, SCHEMATICS, AND DESIGN ARE PROPRIETARY AND CONFIDENTIAL PROPERTY OF INTERNATIONAL HYDRAULICS, INC. DBA: IHI CONNECTORS® IN CLEVELAND, OHIO, AND MAY NOT BE DUPLICATED, USED FOR THE BASIS OF DESIGN OR MANUFACTURE WITHOUT PRIOR WRITTEN PERMISSION OF ITS OWNER. Contents contain a combination of registered trademark, copyright, or patent protections exclusively owned by IHI® which are not to be infringed upon. Not for use where failure creates a hazard to human health or safety. All products are subject to this full disclaimer: ihiconnectors.com/disclaimer.html

$.254 \pm .015$

$.336 \pm .010$

(CENTER)

A/F 7/16"
HEX
(11mm)

$\varnothing .230^{+.010}_{-.005}$
.375 DP.

WASHER
O.D. 12mm

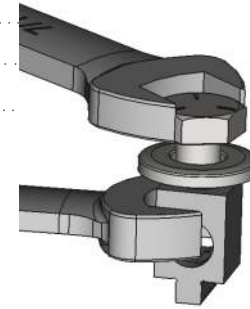

Ring Lug Mount (RLM) Screw Tightening Torques

All torques in inch-lbs. (Divide by 8.85 for N-m)

When Using	THT Mounts		SMT Mount	Lug body Wrench Size
	Min	Max		
-RLM			##	11/32" (9mm)
B6A-PCB-45	35	37-80**	##	

(**) Use of an open ended wrench on the lug to counter the applied torque is recommended in case the soldered mount to PCB is compromised by excessive torque applied through to the soldered PCB joint.

(##) All SMT mounts require that the torque applied should be established by purchaser using data on the strength of the SMT joint in the worst case.

In addition, use of an open ended wrench on the SMT mounted lug to counter the applied torque is recommended in case the soldered mount to PCB is compromised by excessive torque applied through to the soldered PCB joint.

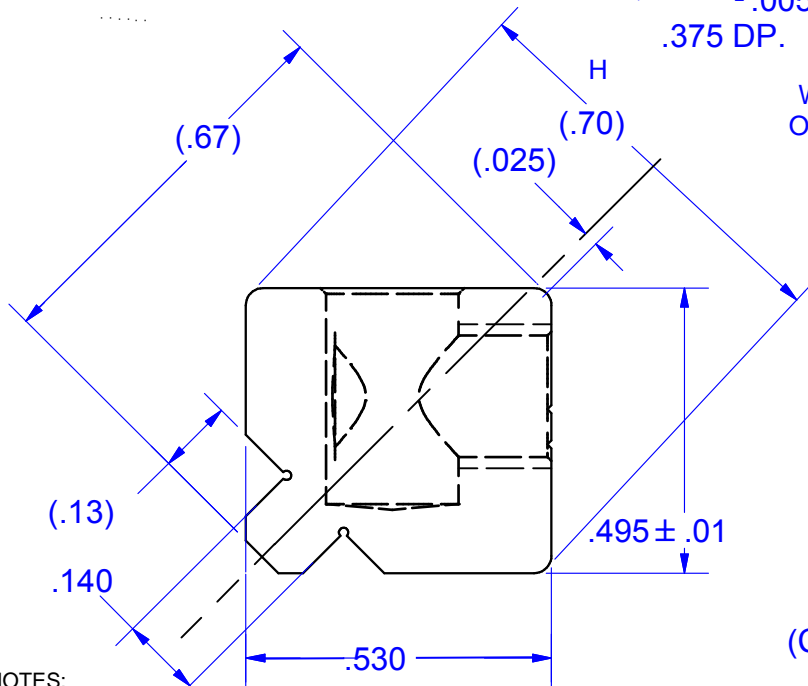

(CNTR)

1/4-28 UNF - 2B

$.307 \pm .015$

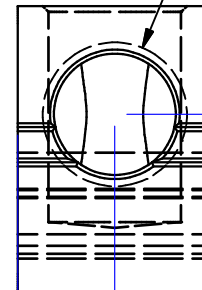
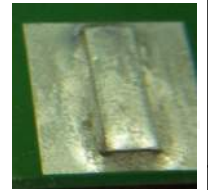

FIG 1 NOTE 11

SMT MODE



THT MODE

NOTES:

- 1.FINISH: TIN PLATE FOR SOLDERING.
- 2.PART IS NOT UL/CSA LISTED/CERTIFIED BUT IS CAPABLE OF PASSING UL486 SUBJECT TO TESTING AS MOUNTED IN PCB.
- 3.WAVE SOLDERABLE (THT) OR SOLDER PASTE SOLDERABLE (SMT)
- 4.THT FOOT MOUNT (45 DEGREE ORIENTATION) OR SMT / SMD MODE IN 90 / 0 DEGREE ORIENTATION.
- 5.ACCEPTS COPPER OR ALUMINUM WIRE (SOLID OR STRANDED)
- 6.FOR .06 PCB MIN. BOARD THICKNESS.
- 7.USE ROUTED SLOT IN PCB FOR .140 FOOT, ALL FINAL PCB SPECS BASED ON BUYER TESTING AND APPROVAL
- 8.SEE ADDITIONAL SPEC SHEETS FOR PAD DESIGN
- 9.RING LUG MOUNT PARTS ARE SUPPLIED WITH HARDWARE KITTED; NOT ASSEMBLED.
- 10.FOR USE WITH CUSTOMER SUPPLIED RING LUGS (1/4"/6MM BOLT SIZE)
- 11.WHEN USING A RING LUG AND BOLT, IT'S RECOMMENDED THAT THE HEAD OF THE BOLT HANGS OFF THE EDGE OF THE BOARD. LITTLE OR NO CLEARANCE BETWEEN THE HEAD OF THE BOLT AND THE BOARD CAN RESULT IN MECHANICAL AND ELECTRICAL FOULING. (FIG 1)

FOR FURTHER INFORMATION ON THE PROPER USE OF THIS PRODUCT IN SPECIFIC APPLICATIONS SEE: ihiconnectors.com/Precautions-when-using-SMT.pdf
ihiconnectors.com/GuideToFlexFlexibleFineStrandedWireCableMechanicalLugsFAQ.html
ihiconnectors.com/FAQ_SMT_SMD_High_CurrentPCB_Terminal_LugsSolderCreep.htm
[ihiconnectors.com/NOTESonPCBFootPrintLayouts\(SMT-SMD-Mode\).pdf](http://ihiconnectors.com/NOTESonPCBFootPrintLayouts(SMT-SMD-Mode).pdf)
ihiconnectors.com/High_Amp_Wide_Trace_PCB_Wire_Connection.html
ihiconnectors.com/Technical-Data-Installation.htm

THIS DRAWING AND DESIGN ARE THE PROPERTY OF INTERNATIONAL HYDRAULICS, INC., CLEVELAND, OHIO, AND MAY NOT BE DUPLICATED, USED FOR THE BASIS OF DESIGN OR MANUFACTURE WITHOUT THE WRITTEN PERMISSION OF INTERNATIONAL HYDRAULICS, INC., CLEVELAND, OHIO

INTERNATIONAL HYDRAULICS, INC.

GENERAL TOLERANCES
 $\pm .015 (\pm 0.038)$

TITLE:
RING LUG MOUNT TERMINAL 65 AMP WITH AWG 6 CU WIRE

MATERIAL: 6061-T6

SCALE: DRAWN BY: CDMR

DWG NO.: B6A-PCB-45-RLM-12W

REV:

FINISH: SEE NOTE

DATE: 9/15/2022

SALES PRINT -NOT FOR MFG.

PAGE 1 OF 3. RECOMMENDED PCB THICKNESS .06"-.093". PLATED VIAS, DOUBLE SIDED. DO TORQUE TEST TO ENSURE YOUR SELECTED UL WIRE SIZE SCREW TORQUE REQUIREMENTS & PULL OUTS ARE MET FOR ON BOARD TESTING, AVOID SLOTS TOO NEAR TO BOARD EDGE. SUITABLE FOR WAVE SOLDER WITH SAC SOLDER, PREFLUX AND PREHEAT. SEE TYPICAL WAVE SOLDER PROFILE. AS TOO MANY VARIABLES ARE IN PLAY WITH TYPE OF BOARD AND TEMPERATURE RISE CHOSEN BY DESIGNER ALL DESIGN ASPECTS NEED TO BE TESTED FOR EACH APPLICATION BY USER.

.148
± FOR
USER FIT

IF REQUIRED, THE INSERTION FORCE MAY BE CONTROLLED
USING FRICTION FIT BY INTERFERENCE AT CORNERS

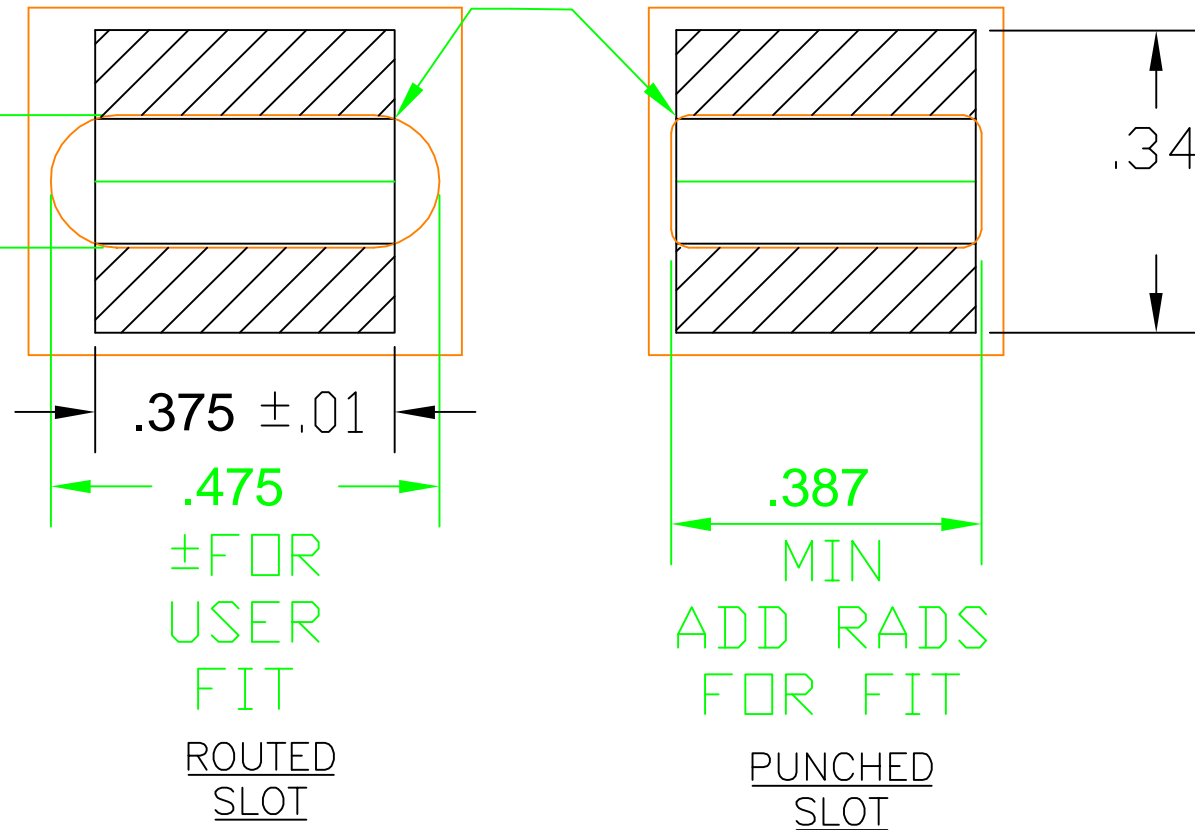

SOLDER FOOT PRINT FOR IHI B4A-PCB-45-XX

IHI Connectors International Hydraulics Inc copyright 2010

ch Zoom Return X Y XY Screen

X

Ach

off

Cch

off

off

off

off

Grid

Time

Temp

Zone

300

270

240

210

180

150

120

90

60

30

0

-1

0:00

1:00

2:00

3:00

4:00

5:00

6:00

7:00

8:00

9 Min

0:00

0:43

1:26

2:09

2:51

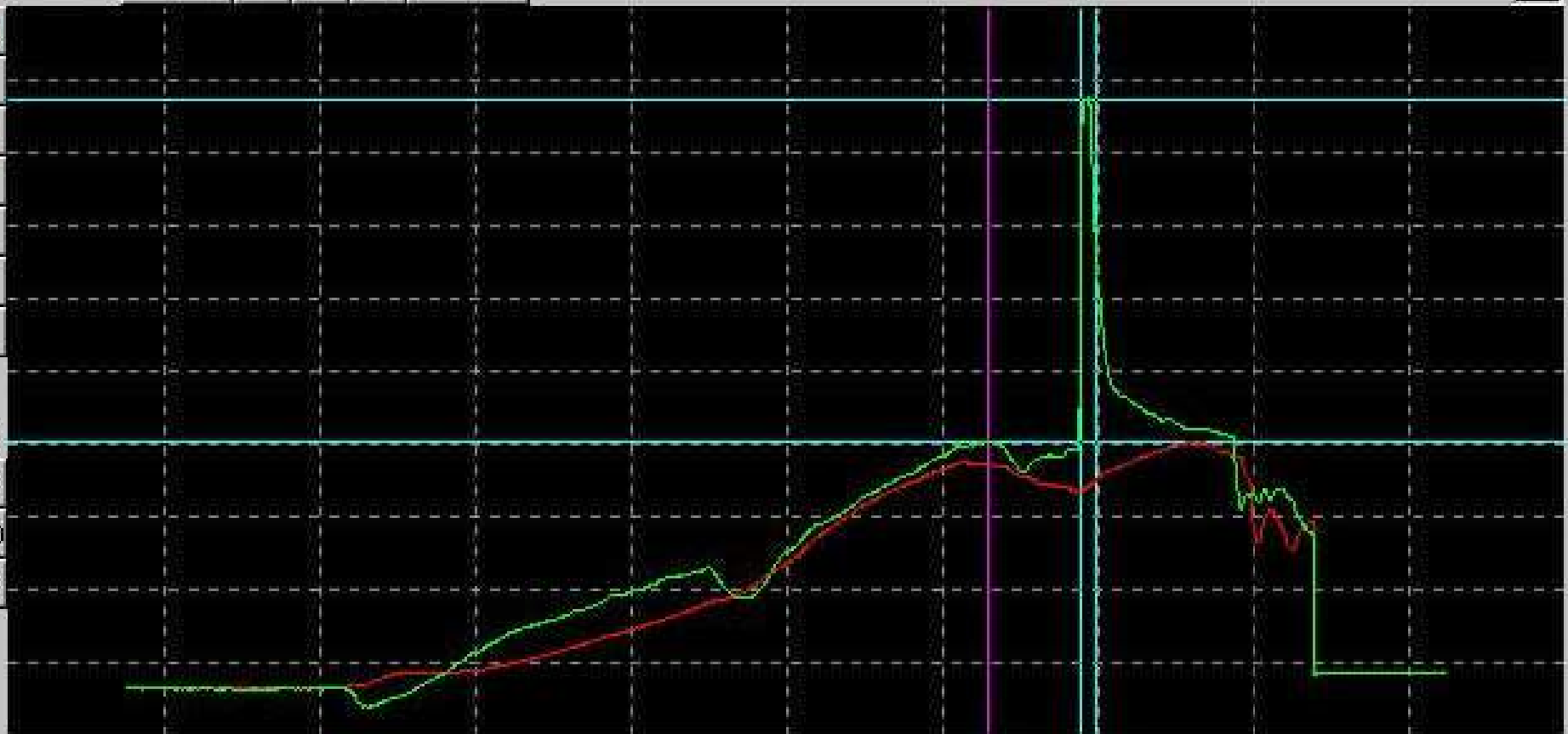



23 January 1998

Best wishes for the New Year! This past year has been very successful for Morningstar, as we have now shipped over 50,000 of our ProStar and SunSaver controllers. We wish to thank you for your interest in our controllers, and we look forward to continued success in 1998.

Enclosed for your review is an Accelerated Reliability Testing Report.

Morningstar recently completed highly accelerated testing of the ProStar and SunSaver controllers. Both controllers survived the testing with remarkable success:

	<u>ProStar</u>	<u>SunSaver</u>
<u>Operating Limits:</u>	-50°C (LCD)	< -100°C
	-90°C (no LCD)	
	+95°C	> +120°C
	45 Grms	> 50 Grms
<u>Destruct Limits:</u>	< -100°C	< -100°C
	+120°C	> +120°C
	50 Grms	> 50 Grms

Since these are first generation products, it is especially important to stress test the limits of the designs for future models. We plan to introduce several new controllers in 1998. This testing identifies areas of the designs that can be upgraded to further expand the safety margins for reliability and durability in the field.

Equally important, we can also have the confidence that our second generation controllers will equal or exceed the success we have had with our first controller designs.

Best regards,

A handwritten signature in cursive script, appearing to read 'Lee S. Gordon', with a horizontal line underneath it.

Lee S. Gordon



ACCELERATED RELIABILITY TESTING
-- ProStar and SunSaver Controllers: July 1997 --

1. Objective

Developmental HALT (Highly Accelerated Life Testing) is an intensive process to uncover design and manufacturing weaknesses in an electronic product. The test units are subjected to progressively higher stress levels by extreme temperature transitions, vibration, and combined environments. The intent is to stress the product well beyond normal operating conditions and determine the operating and destruct limits of the product.

As each failure occurs, the failure is repaired so testing can continue to higher stress levels. This allows a sequence of failures to occur up to the extreme stress limits.

The ultimate goal is to determine the root cause of each failure, and then correct each failure mode. This process can allow the product to reach the fundamental limit of its technology. This will dramatically reduce failures in the field due to aging or other stressful operating conditions.

2. Test Procedure

ProStar and SunSaver controllers were tested by QualMark Corporation in July 1997. A Morningstar engineer was present to repair failures and support the testing. Sandia National Labs also provided support for this testing.

Before beginning the HALT testing, four controllers were subjected to HAST testing. The HAST process is a relatively new test program, and it creates a high-temperature, high-pressure and high-humidity environment in a QualMark test chamber. Two ProStars and two SunSavers were placed in the chamber and powered up without loads for 200 hours.

For the HALT testing, three ProStar controllers and two SunSaver controllers were tested. To find the operating and destruct limits

of the ProStar and SunSaver designs, four groups of tests were done. These tests included the following:

- Thermal Step Stress
- Rapid Thermal Transitions
- Vibration Step Stress
- Combined Environment

Each controller on test was operated under load. The PV input was connected to a dc power supply at 13.5 volts, and the output was loaded between 2 and 10 amps.

Each ProStar was subjected to 3 of the 4 HALT tests, and each SunSaver was subjected to all 4 tests.

3. HAST Test

The test units are stressed to failure in an accelerated time under the following conditions:

- 110°C temperature
- 85% relative humidity
- 1.20 atmospheric pressure
- 200 hours duration

HAST testing duplicates failure modes that result from the standard 85/85 testing, but the tests take far less time.

Overall the test controllers performed very well, with 3 of the 4 units still functional after the test. Although some components cracked or failed, this was expected. While the bare board assemblies only suffered minor damage, the value of the conformal coating protection was evident.

4. Thermal Step Stress Test

Each test controller was subjected to cold thermal steps by decreasing the temperature from +20°C to -100°C in 10°C increments. The hot thermal steps range from +40°C to +120°C with the same increments. The controllers were operated through a full functional test sequence at each temperature.

The controllers passed each temperature step with the following exceptions or comments:

	<u>ProStar</u>	<u>ProStar-LCD</u>	<u>SunSaver</u>
- 60°C	pass	fail ¹	pass
- 100°C	pass	fail ²	pass
+ 60°C	pass ³	pass	pass
+ 100°C	pass	fail ⁴	pass
+ 120°C	pass	fail ⁵	pass

Notes:

- 1 - The LCD display was not visible
- 2 - The LCD meter amplifier became unstable
- 3 - The ProStar overtemperature protection circuit was manually disabled to continue the tests
- 4 - The LCD display was not legible
- 5 - The LCD driver was damaged

5. Rapid Thermal Transition Test

Each controller was subjected to 5 rapid temperature cycles from -100°C to +100°C. The rate of temperature change was 65°C per minute (i.e. 200°C temperature change in 3 minutes). The units remained at each temperature extreme for 10 minutes.

All of the test units passed with no problems or comments with one exception. The exception was a ProStar meter unit that failed after the 4th cycle to +100°C when the red disconnect button case softened and stuck in the disconnect position during the function test check. The button released and continued to function normally during the next cold cycle.

6. Vibration Step Stress Test

Each controller was subjected to vibration steps that began at 5 Grms and increased in 5 Grms increments up to 50 Grms. Each vibration step was continued for 10 minutes. All testing was done at 20°C. Vibration was applied in 6 axes (rotational / directional).

The SunSaver units passed all the tests with no problems. The ProStar units passed without problem up to 50 Grms. At 50 Grms the following failures occurred:

- 2 ProStar units had FET leads break

- 1 ProStar LCD capacitor had a lead break

The 50 G forces imposed on the controllers were at the limit of the test equipment.

7. Combined Environment Test

After completing the tests above, each unit was finally subjected to rapid temperature cycles from -100°C to +100°C combined with vibration. The thermal transitions were very fast (3 minutes), and at the end of each thermal cycle the vibration was increased by 10 Grms for a 10 minute interval.

This resulted in 6 thermal cycles, each with a 200°C temperature range, and vibration levels increasing from 10 Grms up to 50 Grms.

There were some additional FET and capacitor failures on the ProStar. The SunSaver passed all the tests.

8. Summary

The SunSaver and ProStar controllers (both first generation designs) passed the HAST and HALT testing with remarkable success. The test results far exceeded the best expectations of Morningstar.

The controller models as tested (i.e. before any design modifications or improvements) were given the following Operating and Destruct Limits by QualMark:

	<u>ProStar</u>	<u>SunSaver</u>
<u>Operating Limits:</u>	-50°C (LCD) -90°C (no LCD) +95°C 45 Grms	< -100°C > +120°C > 50 Grms
<u>Destruct Limits:</u>	< -100°C +120°C 50 Grms	< -100°C > +120°C > 50 Grms

The "<" and ">" signs indicate that the rating exceeds the limits of the test setup and equipment.

Some basic design upgrades will significantly extend the operating limits of the ProStar controllers. The purpose of this HAST/HALT testing is to identify areas of the design that can be modified to increase the limits of the device. Morningstar will address the following areas for the second generation ProStar design:

- replace leaded parts with surface mount parts
- modify the LCD meter circuit (an upgraded and more simple meter circuit design has been in progress)
- upgrade the red disconnect button
- replace the battery select pin with a rotary switch (one pin was damaged in the vibration testing, and this replacement had already been identified)
- upgrade the calibration process (the HAST testing caused a small drift, and upgraded methods of calibration have been identified)

Morningstar's goal is to expand the operating and destruct limits of the company's products with continuous design improvements. Even though the first generation designs provided very high limits, expanding these limits will further reduce the effects of aging and ensure very high reliability margins over a long period of time.

R1-Dec97