

FIG. 1

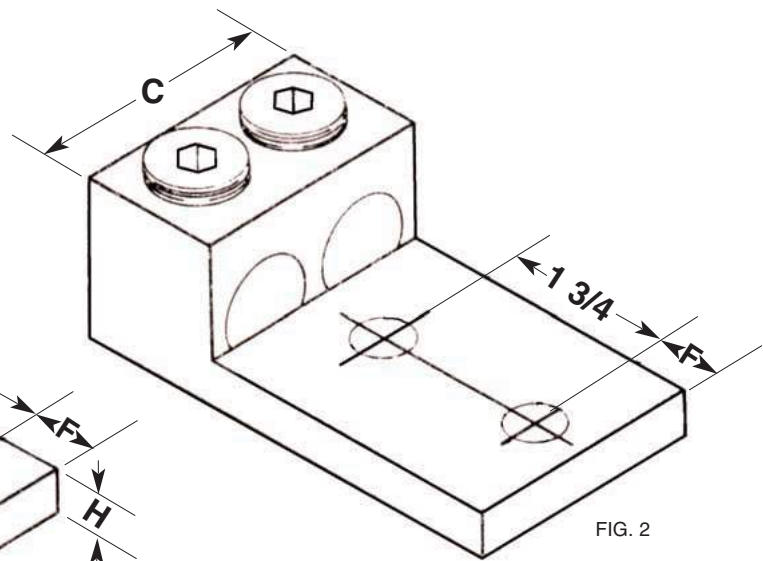

FIG. 2

CAT. NO.	FIG.	WIRE RANGE CU9AL	A	B	C	D	E	F	H
2/0L2	1	2/0-14	3.875	1.125	0.750	.265	0.875	0.344	0.312
250L2	1	250 MCM-6	4.000	1.187	0.875	0.406	1.000	0.625	0.312
350L2	1	350 MCM-6	4.312	1.375	1.125	0.562	1.312	0.625	0.312
600L2	1	600 MCM-2	4.500	1.562	1.500	0.562	1.375	0.625	0.437
800L2	1	800 MCM-300 MCM	4.750	1.750	1.750	0.562	1.625	0.625	0.500
1000L2	1	1000 MCM-500 MCM	4.750	1.750	1.750	0.562	1.625	0.625	0.500
2-2/0L2	2	2/0-14	3.875	1.125	1.250	.265	0.875	0.344	0.312
2-250L2	2	250 MCM-6	4.000	1.187	1.812	0.406	1.000	0.625	0.312
2-350L2	2	350 MCM-6	4.312	1.375	2	0.562	1.312	0.625	0.312
2-600L2	2	600 MCM-2	4.500	1.562	2.406	0.562	1.375	0.625	0.437
2-800L2	2	800 MCM-300 MCM	4.750	1.750	3.187	0.562	1.625	0.625	0.5
2-1000L2	2	1000 MCM-500 MCM	4.750	1.750	3.187	0.562	1.625	0.625	0.5

**Material:** High Strength, High Conductive Aluminum Alloy 6061T6

**Plating:** Tin Over Copper