



Single Lug - Al

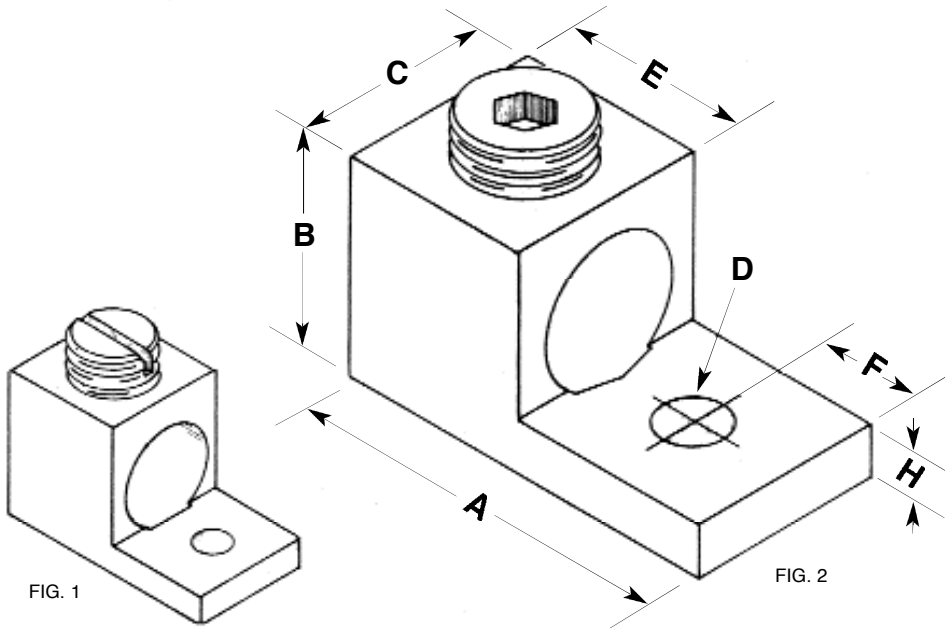

FIG. 1

FIG. 2

CAT. NO.	FIG.	WIRE RANGE CU9AL							
			A	B	C	D	E	F	H
800T	2	800 MCM-300 MCM	3.375	1.937	1.575	0.656	1.625	0.875	0.5

Material: High Strength, High Conductive Aluminum Alloy 6061T6

Plating: Tin Over Copper