

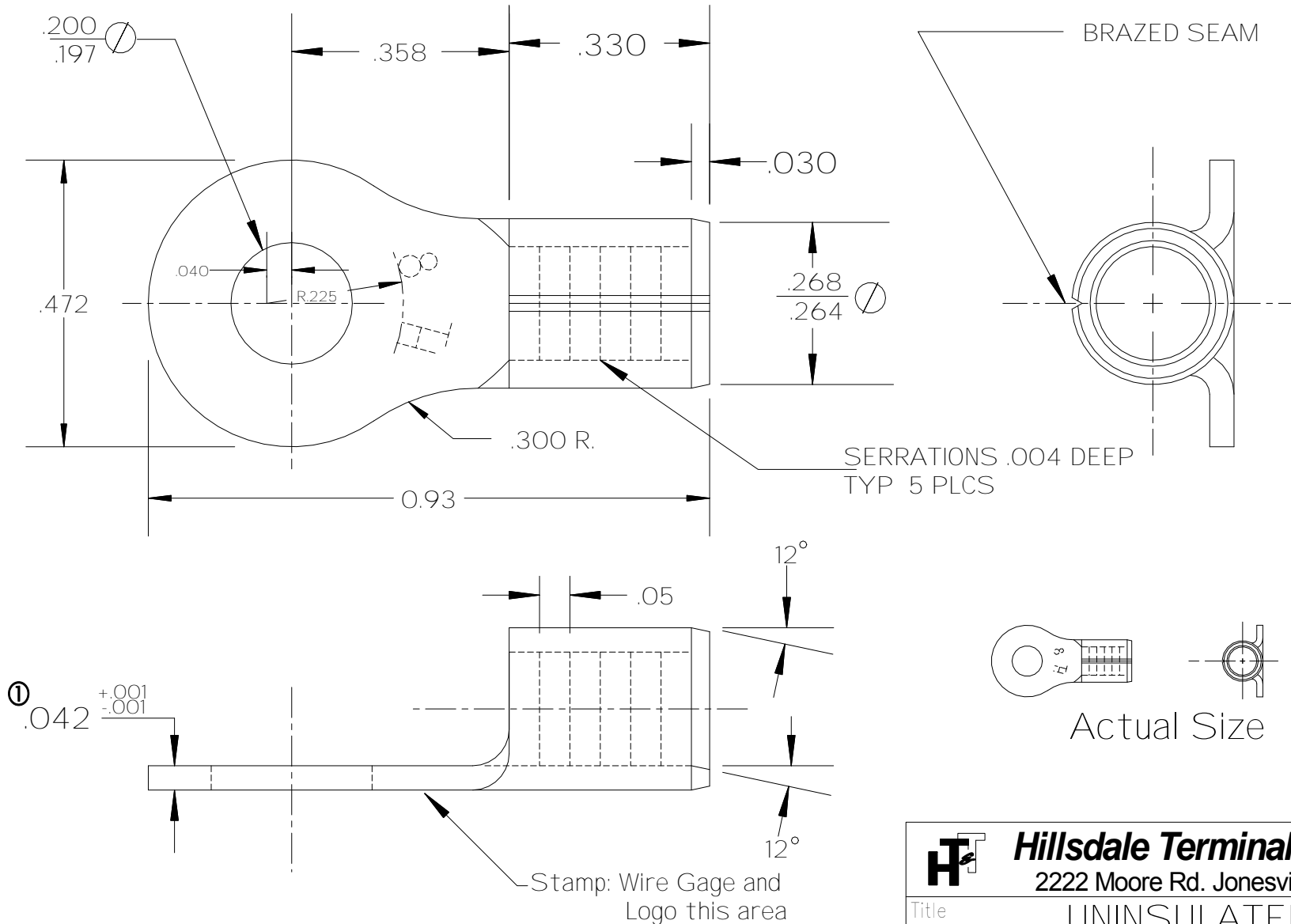

Num	Date	By	Revision Note
1	06/01/07	jim	was .044

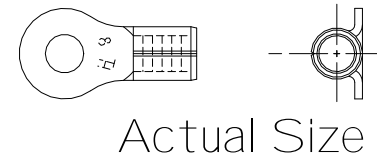

1. Material: Alloy 110 Copper-1/2 Hard Temper
2. Finish: Flash Electro Tin Plate



 Hillsdale Terminal & Tools 2222 Moore Rd. Jonesville Mi. 49250	
Title UNINSULATED 8 GA. #8, #10 STUD RING	
Drawn by J. Condon	Date 08/27/95
Checked by	Scale 4X
Material See Notes	Drawing # 10610