

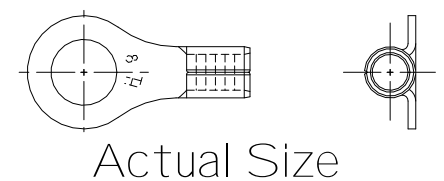

Num	Date	By	Revision Note
1	06/01/07	jim	was .044
2	04/01/11	jim	was .343/.340

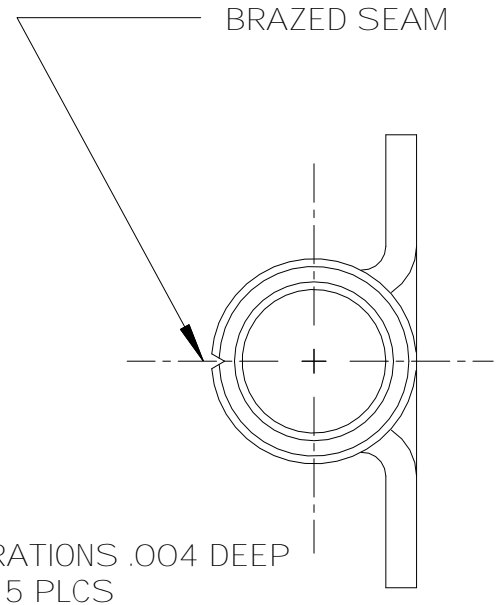
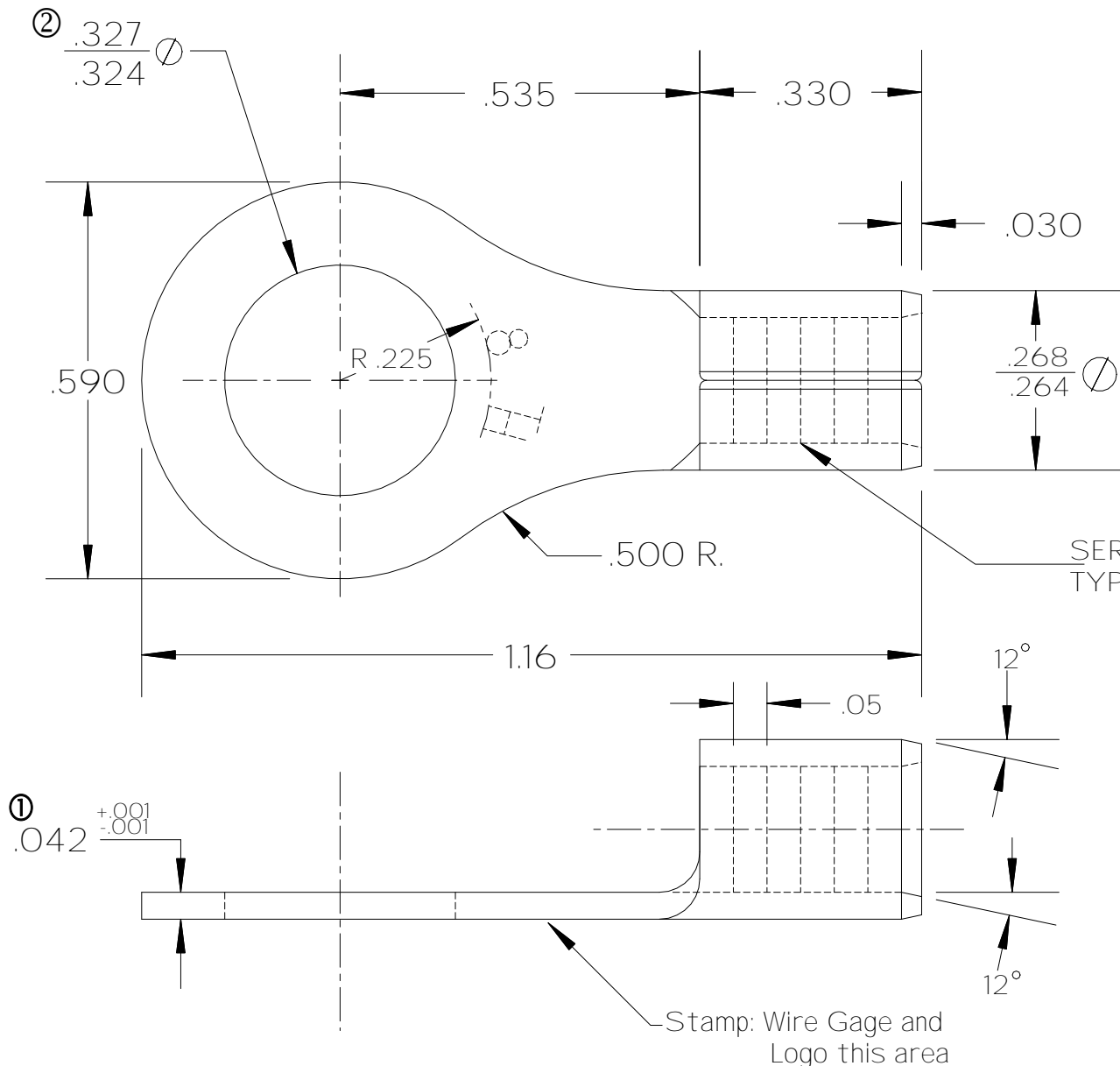

1. Material: Alloy 110 Copper-1/2 Hard Temper
2. Finish: Flash Electro Tin Plate

 Hillsdale Terminal & Tools 2222 Moore Rd. Jonesville Mi. 49250	Title UNINSULATED	
	8 GA. 5/16 STUD RING	
Drawn by J. Condon	Date	08/27/95
Checked by	Scale	4X
Material See Notes	Drawing #	10612