

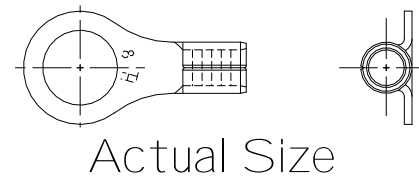

Num	Date	By	Revision Note
1	06/01/07	jim	was .044

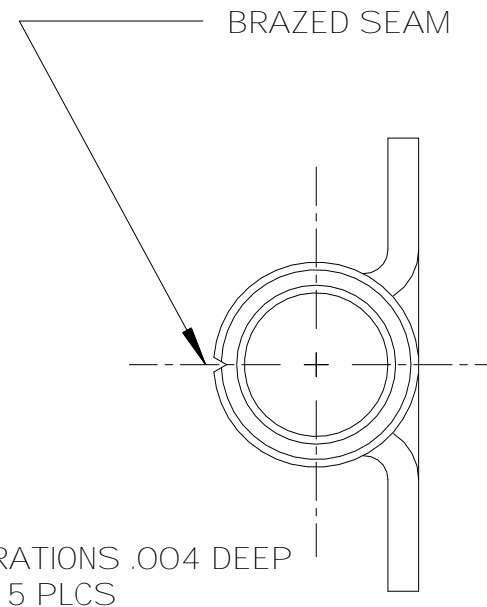
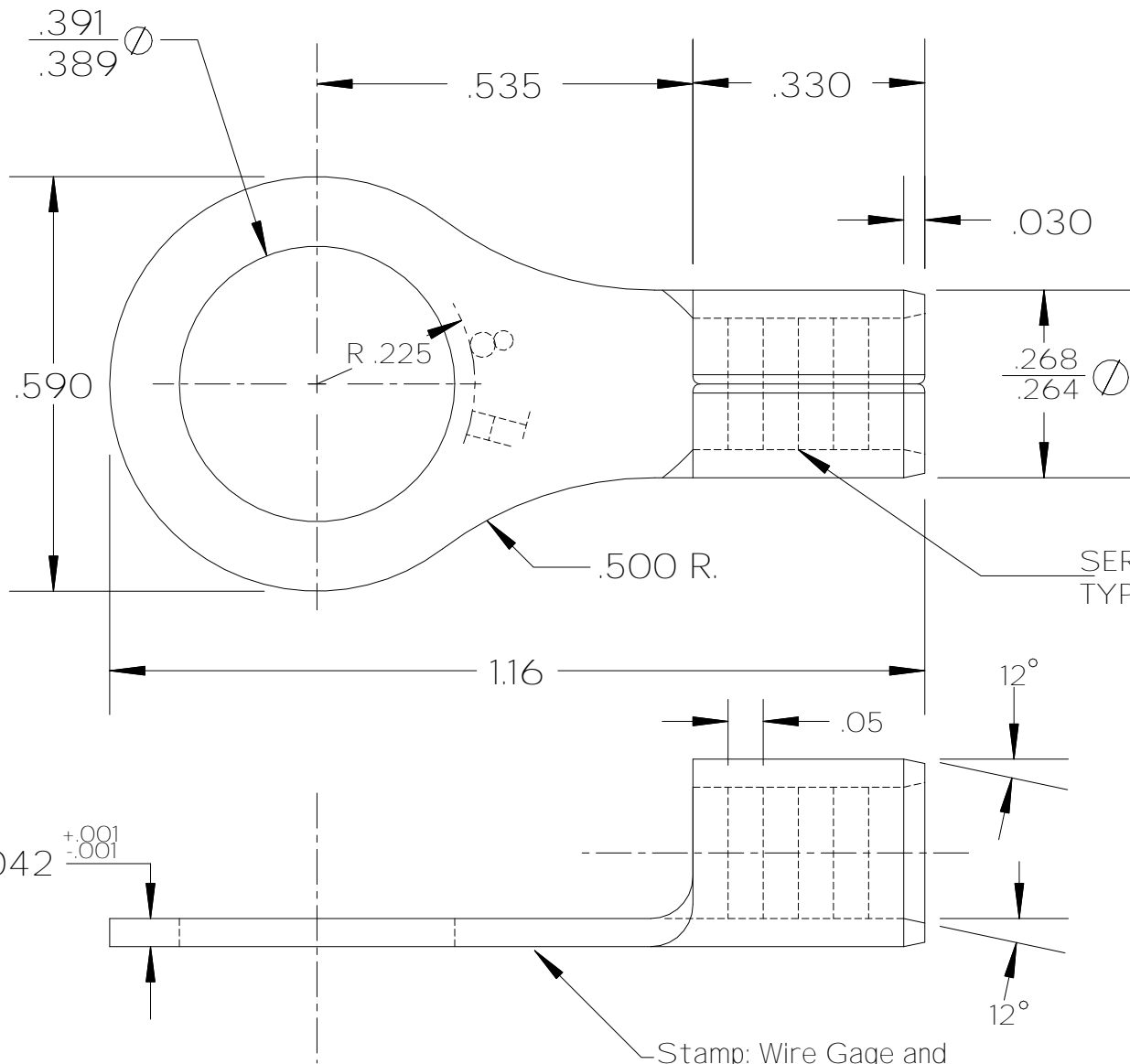

1. Material: Alloy 110 Copper-1/2 Hard Temper
2. Finish: Flash Electro Tin Plate

Stamp: Wire Gage and Logo this area

 Hillsdale Terminal & Tools 2222 Moore Rd. Jonesville Mi. 49250	
Title UNINSULATED 8 GA. 3/8 STUD RING	
Drawn by J. Condon	Date 08/27/95
Checked by	Scale 4X
Material See Notes	Drawing # 10613