

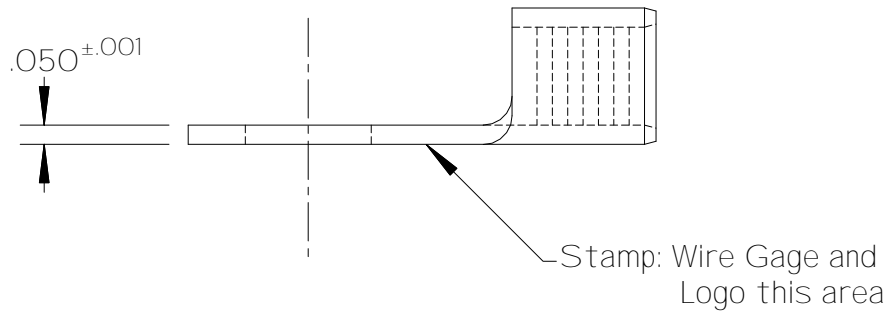

10617 5/16" = .328 \varnothing
 10618 3/8" = .400 \varnothing

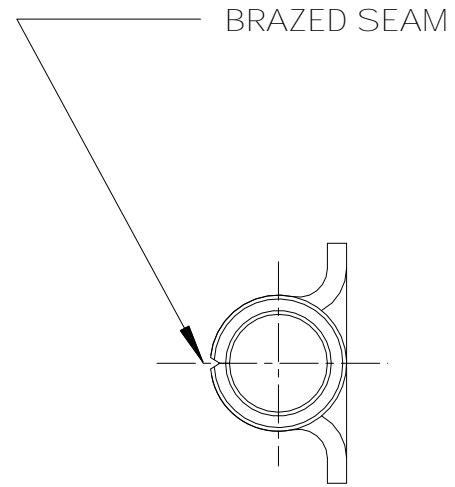
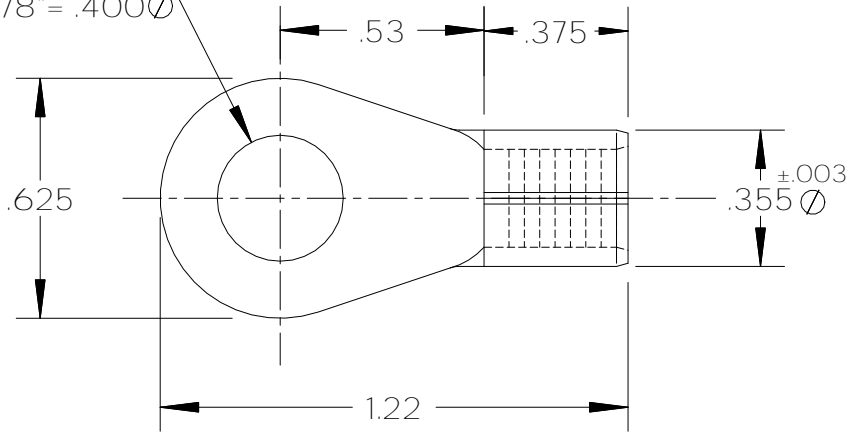

1. Material: Alloy 110 Copper-1/2 Hard Temper
2. Finish: Flash Electro Tin Plate

 Hillsdale Terminal & Tools 2222 Moore Rd. Jonesville Mi. 49250	
Title Uninsulated 6 GA. 5/16" & 3/8" Stud Ring	
Drawn by J. Condon	Date 03/01/01
Checked by	Scale 2X Size
Material	Drawing # 10617-18