

UNLESS OTHERWISE SPECIFIED, DIMENSIONS ARE IN INCHES. REMOVE ALL BURRS AND SHARP EDGES.

THIS DRAWING AND DESIGN ARE THE PROPERTY OF INTERNATIONAL HYDRAULICS, INC., MENTOR, OHIO. IT MAY NOT BE DUPLICATED OR USED FOR THE BASIS OF DESIGN OR MANUFACTURE, WITHOUT THE WRITTEN PERMISSION OF INTERNATIONAL HYDRAULICS, INC.

REVISIONS

TOLERANCES: $\pm .015$

NR.	DESCRIPTION	BY	DATE

NOT FOR USE WHERE FAILURE CREATES A HAZARD TO HUMAN HEALTH OR SAFETY. ALL PRODUCTS ARE SUBJECT TO THIS FULL DISCLAIMER: <http://www.ihiconnectors.com/disclaimer.html>

FOR FURTHER INFORMATION ON THE PROPER USE OF THIS PRODUCT IN SPECIFIC APPLICATIONS SEE <http://www.ihiconnectors.com/GuideToFlexFlexibleFineStrandedWireCableMechanicalLugsFAQ.html>
<http://www.ihiconnectors.com/Technical-Data-Installation.htm>

UL LISTED, CSA CERTIFIED
 MARKING ON PART
 "UL CSA
 CU9AL
 1/0-14
 IHI S1/0"

Tightening Torques
 1/0-3 AWG 50 in-lb
 4-6 AWG 45 in-lb
 8 AWG 40 in-lb
 10-14 AWG 35 in-lb

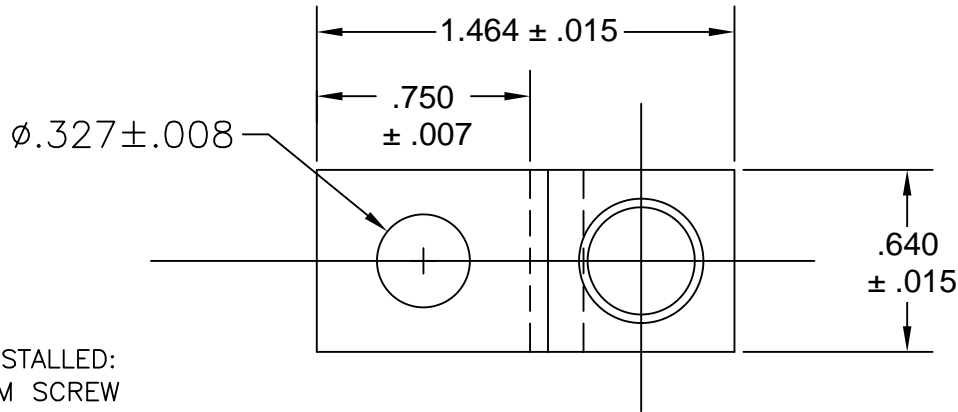

INSTALLED:
 1 X 7/16-20 ALUM SCREW

PART NO S1/0-TP:
 SLOTTED DRIVE

PART NO. S1/0-TP-HEX:
 3/16 A/F HEX SOCKET DRIVE

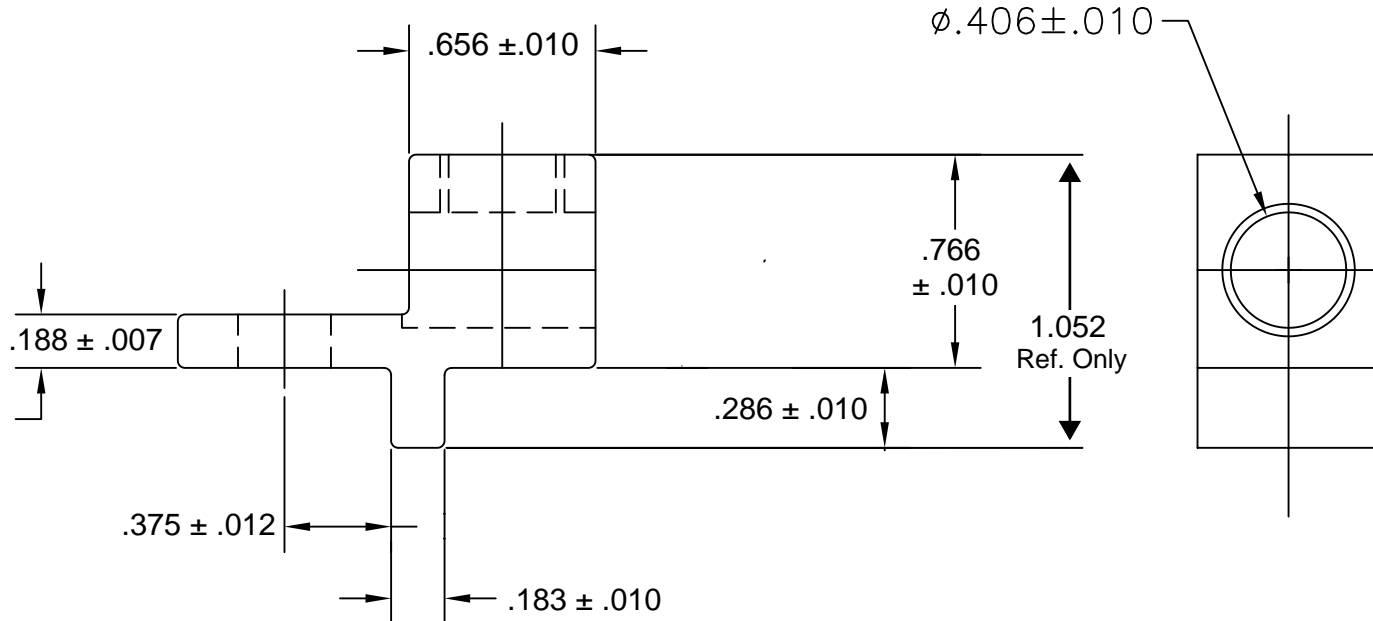

International Hydraulics
 7700 ST. CLAIR AVE., MENTOR, OH

DWN BY: CDMR	TITLE: DUAL RATED 1/0 Turn Prevent Lug	REV#
DATE: 8/17/07 1/23/15	MATERIAL: 6061-T6 TIN PLTD	FINISH
		DWG# S1/0-TP-XX