

SCREW#12786HEX  
(STEEL)

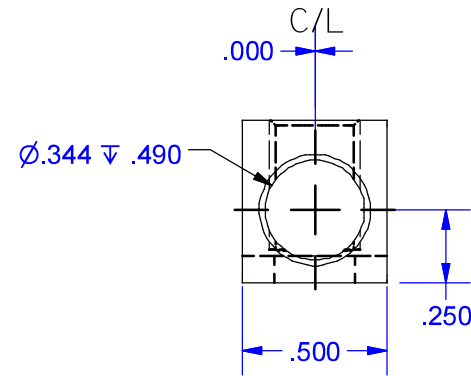
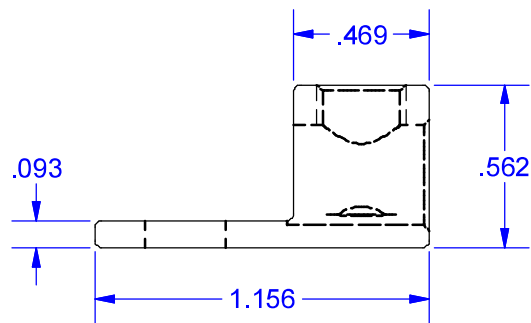

**MARKING**

S2  
IHI  
2-14  
CU9AL  
UL LOGO  
CSA LOGO

NOT FOR USE WHERE FAILURE CREATES A HAZARD TO HUMAN HEALTH OR SAFETY. ALL PRODUCTS ARE SUBJECT TO THIS FULL DISCLAIMER: <http://www.ihconnectors.com/disclaimer.html>

FOR FURTHER INFORMATION ON THE PROPER USE OF THIS PRODUCT IN SPECIFIC APPLICATIONS SEE <http://www.ihconnectors.com/GuideToFlexFlexibleFineStrandedWireCableMechanicalLugsFAQ.html> <http://www.ihconnectors.com/Technical-Data-Installation.htm>

THIS DRAWING AND DESIGN ARE THE PROPERTY OF INTERNATIONAL HYDRAULICS, INC., CLEVELAND, OHIO, AND MAY NOT BE DUPLICATED, USED FOR THE BASIS OF DESIGN OR MANUFACTURE WITHOUT THE WRITTEN PERMISSION OF INTERNATIONAL HYDRAULICS, INC., CLEVELAND, OHIO.		INTERNATIONAL HYDRAULICS, INC.	
<b>GENERAL TOLERANCES ±.015 (±0.038)</b>		TITLE: <b>S2 -HEX CONNECTOR</b>	
MATERIAL: <b>6061-T6 (EXT1011)</b>	SIZE:	DRAWN BY: <b>TDS</b>	DWG NO.: <b>S2-HEX(SALES)</b>
FINISH: <b>TIN PLATE EMS</b>	DATE: <b>4/22/09</b>	REV: <b>THIS IS A CAD DRAWING, DO NOT MANUALLY REVISE</b>	