

SCREW# 12786  
(STEEL)

5/16-24 UNF-2B SLOTTED  
ASSEMBLE SCREW SNUG  
TO BOTTOM 2-15in.-lbs.

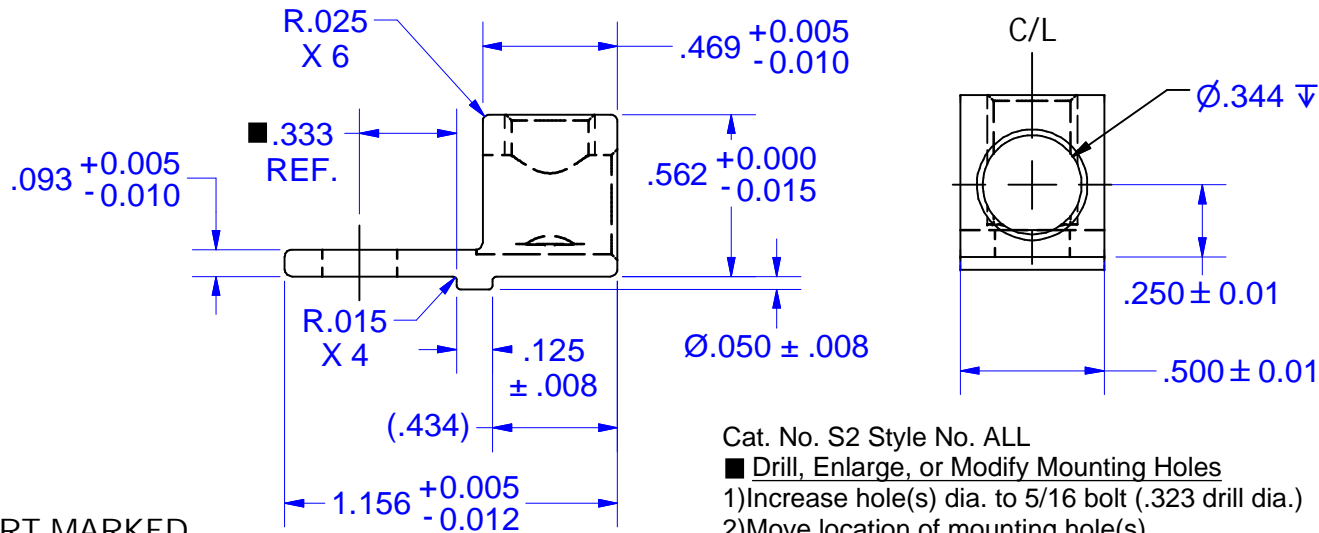

Cat. No. S2 Style No. ALL  
 ■ Drill, Enlarge, or Modify Mounting Holes  
 1) Increase hole(s) dia. to 5/16 bolt (.323 drill dia.)  
 2) Move location of mounting hole(s)  
 3) If buying blank lug, put custom hole(s) in.

IHI UL/CSA Installation Guide to Drill or Enlarge Mounting Holes:  
<https://lugsdirect.com/PDF%20Documents/IHI-MTG-HOLE-FIELD-MODS-UL&CSA-CERTIFICATIONS.pdf>

PART MARKED  
 S2  
 IHI Logo  
 UL Logo  
 CSA Logo  
 2-14  
 CU9AL

2-14 AWG. WIRE CONNECTOR  
 REF. 2700-1001 (ASSY.)

NOT FOR USE WHERE FAILURE CREATES A HAZARD TO HUMAN HEALTH OR SAFETY. ALL PRODUCTS ARE SUBJECT TO THIS FULL DISCLAIMER: <http://www.ihiconnectors.com/disclaimer.html>

FOR FURTHER INFORMATION ON THE PROPER USE OF THIS PRODUCT IN SPECIFIC APPLICATIONS SEE <http://www.ihiconnectors.com/GuideToFlexFlexibleFineStrandedWireCableMechanicalLugsFAQ.html> <http://www.ihiconnectors.com/Technical-Data-Installation.htm>

THIS DRAWING AND DESIGN ARE THE PROPERTY OF INTERNATIONAL HYDRAULICS, INC., CLEVELAND, OHIO, AND MAY NOT BE DUPLICATED, USED FOR THE BASIS OF DESIGN OR MANUFACTURE WITHOUT THE WRITTEN PERMISSION OF INTERNATIONAL HYDRAULICS, INC., CLEVELAND, OHIO.		<b>INTERNATIONAL HYDRAULICS, INC.</b>	
GENERAL TOLERANCES ±.015 (±0.038)		TITLE: <b>S2-TP CONNECTOR</b>	
MATERIAL: <b>6061-T6 (X1011TP)</b>	SIZE:	DRAWN BY: <b>TDS</b>	DWG NO.: <b>S2-TP (SALES)</b>
FINISH: <b>TIN PLATE EMS</b>	DATE: <b>8/26/09</b>	REV: <b>IHI CONNECTORS</b>	