

SCREW # 14237
(ALUMINUM TIN PLATED)

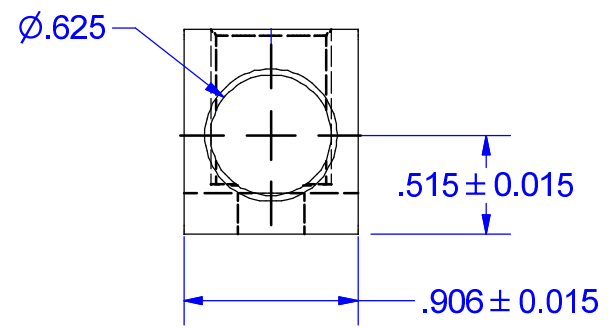
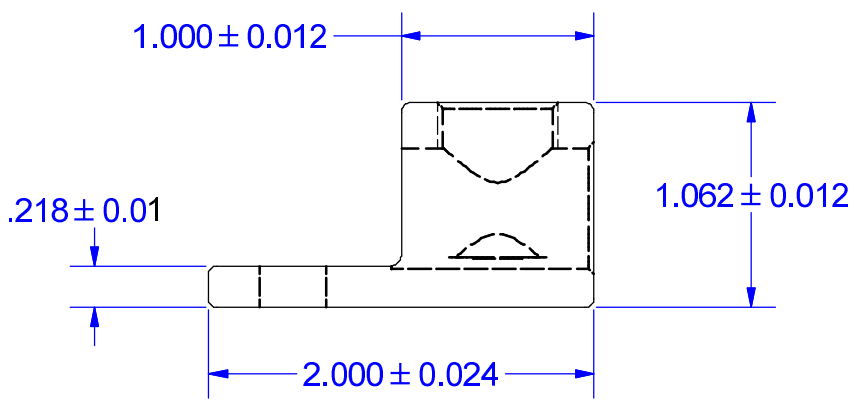

PART MARKED
250 MCM-6
CU9AL
UL Logo
CSA logo
IHI Logo
S250

NOT FOR USE WHERE FAILURE CREATES A HAZARD TO HUMAN HEALTH OR SAFETY. ALL PRODUCTS ARE SUBJECT TO THIS FULL DISCLAIMER: <http://www.ihconnectors.com/disclaimer.html>

FOR FURTHER INFORMATION ON THE PROPER USE OF THIS PRODUCT IN SPECIFIC APPLICATIONS SEE <http://www.ihconnectors.com/GuideToFlexFlexibleFineStrandedWireCableMechanicalLugsFAQ.html> <http://www.ihconnectors.com/Technical-Data-Installation.htm>

THIS DRAWING AND DESIGN ARE THE PROPERTY OF INTERNATIONAL HYDRAULICS, INC., CLEVELAND, OHIO, AND MAY NOT BE DUPLICATED, USED FOR THE BASIS OF DESIGN OR MANUFACTURE WITHOUT THE WRITTEN PERMISSION OF INTERNATIONAL HYDRAULICS, INC., CLEVELAND, OHIO.		INTERNATIONAL HYDRAULICS, INC.		
GENERAL TOLERANCES ±.015 (±0,038)		TITLE: S250-41-44 (WEB) CONNECTOR		
MATERIAL: 6061-T6 (X1003)	SIZE:	DRAWN BY: TDS	DWG NO.: S250-41-44	REV:
FINISH: TIN PLATE EMS	DATE: 2/20/09 05/06/15		IHI CONNECTORS	