

Cat. No. S300 Style No. ALL

■ Drill, Enlarge, or Modify Mounting Holes

- 1) Increase hole(s) dia. to 1/2 bolt (17/32 drill dia.)
- 2) Move location of mounting hole(s)
- 3) If buying blank lug, put custom hole(s) in.

■ FOR 1/4" OR M6 BOLT

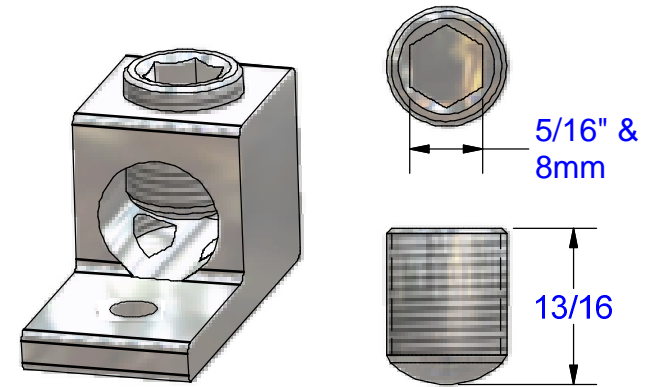
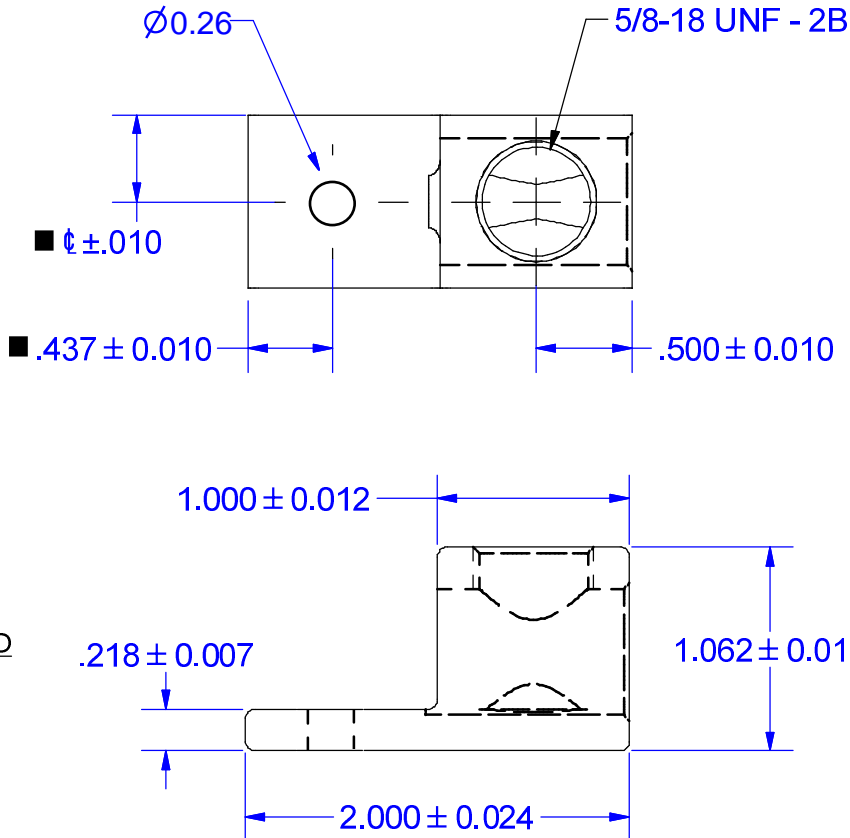

SCREW #14237M
Tin Plated Aluminum

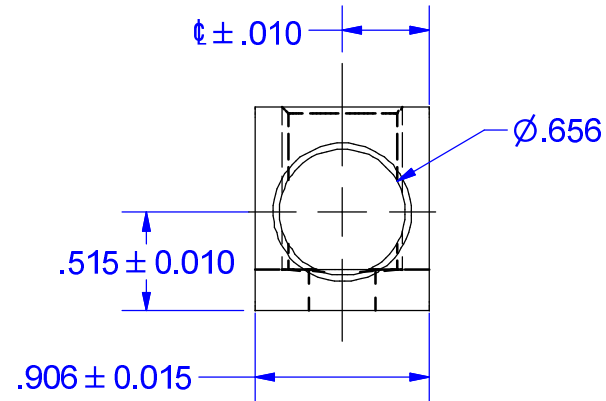

PARTS MARKED
 300 KCMIL-6
 CU9AL
 UL LOGO
 CSA LOGO
 IHI LOGO
 S300

WEB PRINT RELEASED 2-26-2015

NOT FOR USE WHERE FAILURE CREATES A HAZARD TO HUMAN HEALTH OR SAFETY. ALL PRODUCTS ARE SUBJECT TO THIS FULL DISCLAIMER: <http://www.ihiconnectors.com/disclaimer.html>

FOR FURTHER INFORMATION ON THE PROPER USE OF THIS PRODUCT IN SPECIFIC APPLICATIONS SEE <http://www.ihiconnectors.com/GuideToFlexFlexibleFineStrandedWireCableMechanicalLugsFAQ.html>
<http://www.ihiconnectors.com/Technical-Data-Installation.htm>

THIS DRAWING AND DESIGN ARE THE PROPERTY OF INTERNATIONAL HYDRAULICS, INC., CLEVELAND, OHIO, AND MAY NOT BE DUPLICATED, USED FOR THE BASIS OF DESIGN OR MANUFACTURE WITHOUT THE WRITTEN PERMISSION OF INTERNATIONAL HYDRAULICS, INC., CLEVELAND, OHIO.		INTERNATIONAL HYDRAULICS, INC.	
GENERAL TOLERANCES ±.015 (±0.038)		TITLE: S300-26-44-M 1/4" OR M6 BOLT MOUNT 300-6 WIRE RANGE	
MATERIAL: 6061-T6 (X1003)	SIZE:	DRAWN BY: TDS	DWG NO.: S300-26-44-M
FINISH: TIN PLATE EMS	DATE: 1/8/09	REV: THIS IS A CAD DRAWING, DO NOT MANUALLY REVISE	