

SCREW#14241
(ALUMINUM
TIN PLATED)

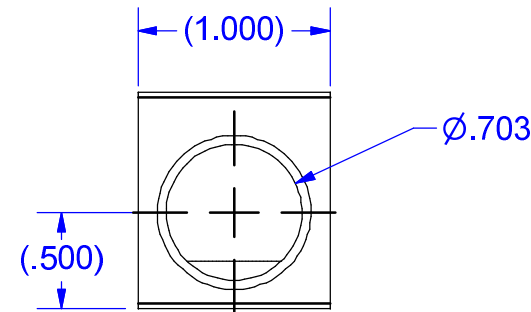
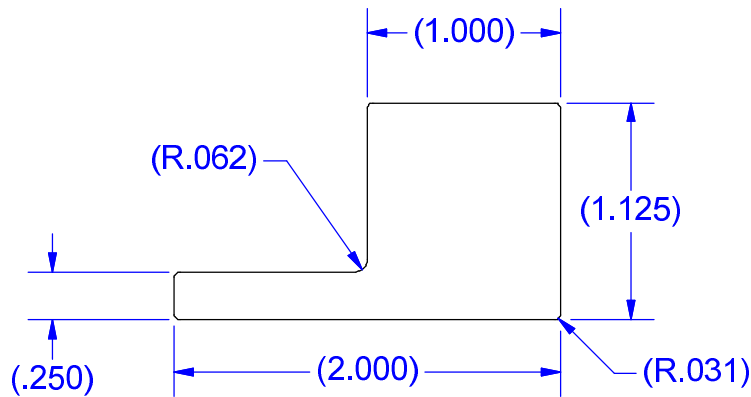

MARKING

S350
 350 KCMIL-6
 CU9AL
 IHI
 CSA LOGO
 UL LOGO

Cat No. S350 Style No. 1

- Drill, Enlarge, or Modify Mounting Holes
- 1) Increase hole(s) dia. to 9/16 bolt
- 2) Move location of mounting hole(s)
- 3) If buying blank lug, put custom hole(s) in.

FLEX WIRE 262 KCMIL - 4 AWG

THIS DRAWING AND DESIGN ARE THE PROPERTY OF INTERNATIONAL HYDRAULICS, INC., CLEVELAND, OHIO, AND MAY NOT BE DUPLICATED, USED FOR THE BASIS OF DESIGN OR MANUFACTURE WITHOUT THE WRITTEN PERMISSION OF INTERNATIONAL HYDRAULICS, INC., CLEVELAND, OHIO.		INTERNATIONAL HYDRAULICS, INC.		
GENERAL TOLERANCES ±.015 (±0,038)		TITLE: S350-41-50 CONNECTOR		
MATERIAL: 6061-T6 (X0010)	SIZE:	DRAWN BY: TDS	DWG NO.: S350-41-50	REV:
FINISH: TIN PLATE EMS	DATE: 12/10/08	THIS IS A CAD DRAWING, DO NOT MANUALLY REVISE		

NOT FOR USE WHERE FAILURE CREATES A HAZARD TO HUMAN HEALTH OR SAFETY. ALL PRODUCTS ARE SUBJECT TO THIS FULL DISCLAIMER: <http://www.ihiconnectors.com/disclaimer.html>

FOR FURTHER INFORMATION ON THE PROPER USE OF THIS PRODUCT IN SPECIFIC APPLICATIONS SEE <http://www.ihiconnectors.com/GuideToFlexFlexibleFineStrandedWireCableMechanicalLugsFAQ.html>
<http://www.ihiconnectors.com/Technical-Data-Installation.htm>