

Examples of Mounting Hole Modifications

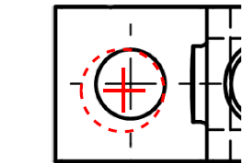

Enlarged hole and shifted center line

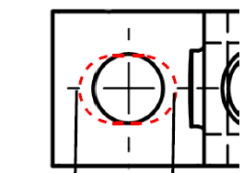

.323

Elongated hole

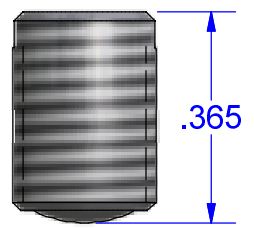
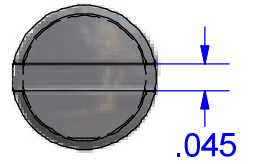
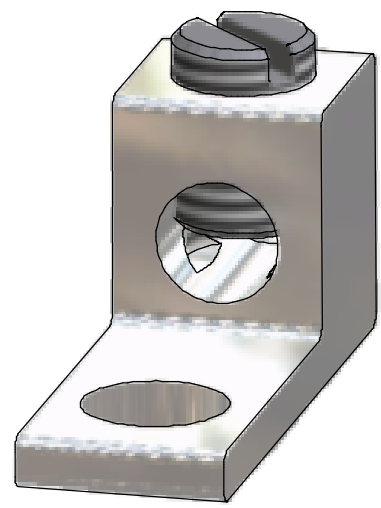

SCREW # 11489/15717
PLATED STEEL

Cat. No. S6 Style No. ALL

■ Drill, Enlarge, or Modify Mounting Holes

- 1) Increase hole(s) dia. to 5/16 bolt (.323 drill dia.)
- 2) Move location of mounting hole(s)
- 3) If buying blank lug, put custom hole(s) in.

IHI UL/CSA Installation Guide to Drill or Enlarge Mounting Holes:

<https://lugsdirect.com/PDF%20Documents/IHI-MTG-HOLE-FIELD-MODS-UL&CSA-CERTIFICATIONS.pdf>

PART MARKED
S6
IHI
UL Logo
CSA Logo
CU9AL
6-14

■ FOR #10 OR M5 MOUNTING BOLT

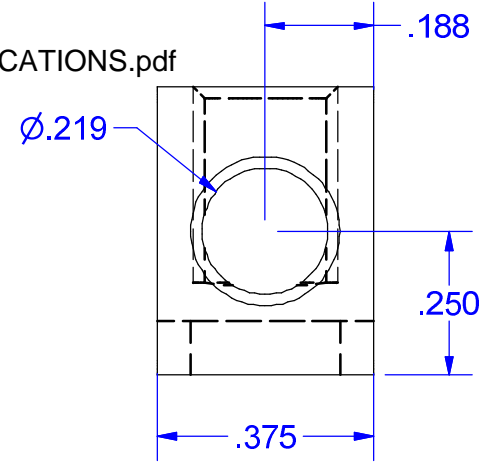
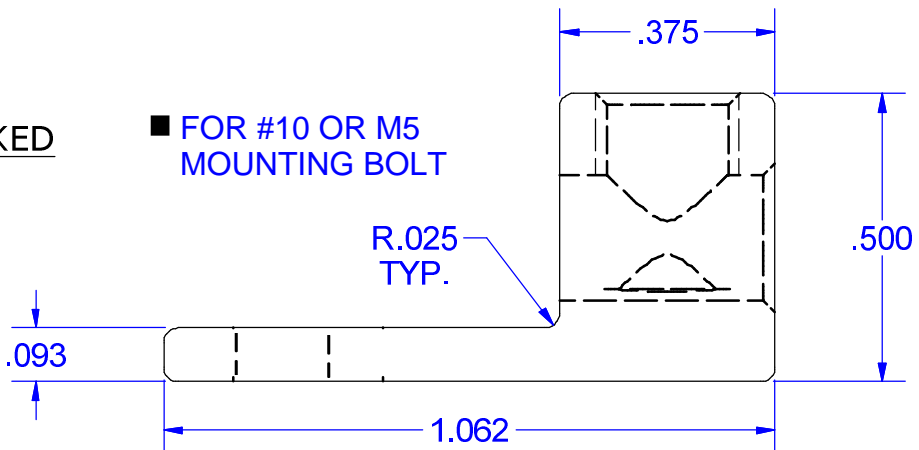

NOT FOR USE WHERE FAILURE CREATES A HAZARD TO HUMAN HEALTH OR SAFETY. ALL PRODUCTS ARE SUBJECT TO THIS FULL DISCLAIMER: <http://www.ihconnectors.com/disclaimer.html>

FOR FURTHER INFORMATION ON THE PROPER USE OF THIS PRODUCT IN SPECIFIC APPLICATIONS SEE <http://www.ihconnectors.com/GuideToFlexFlexibleFineStrandedWireCableMechanicalLugsFAQ.html> <http://www.ihconnectors.com/Technical-Data-Installation.htm>

THIS DRAWING AND DESIGN ARE THE PROPERTY OF INTERNATIONAL HYDRAULICS, INC., CLEVELAND, OHIO, AND MAY NOT BE DUPLICATED, USED FOR THE BASIS OF DESIGN OR MANUFACTURE WITHOUT THE WRITTEN PERMISSION OF INTERNATIONAL HYDRAULICS, INC., CLEVELAND, OHIO.		INTERNATIONAL HYDRAULICS, INC.	
GENERAL TOLERANCES $\pm .015 (\pm 0,038)$		TITLE: S6-203_(WEB) CONNECTOR	
MATERIAL: 6061-T6 EXT1010	SIZE:	DRAWN BY: TDS	DWG NO.: S6-203_(WEB)
FINISH: TIN PLATE EMS	DATE: 4/20/09	REV: 0	IHI CONNECTORS