

IHI UL/CSA Installation Guide to Drill or Enlarge Mounting Holes:  
<https://lugsdirect.com/PDF%20Documents/IHI-MTG-HOLE-FIELD-MODS-UL&CSA-CERTIFICATIONS.pdf>

Cat. No. S2 Style No. ALL

- Drill, Enlarge, or Modify Mounting Holes
- 1) Increase hole(s) dia. to 5/16 bolt (.323 drill dia.)
  - 2) Move location of mounting hole(s)
  - 3) If buying blank lug, put custom hole(s) in.

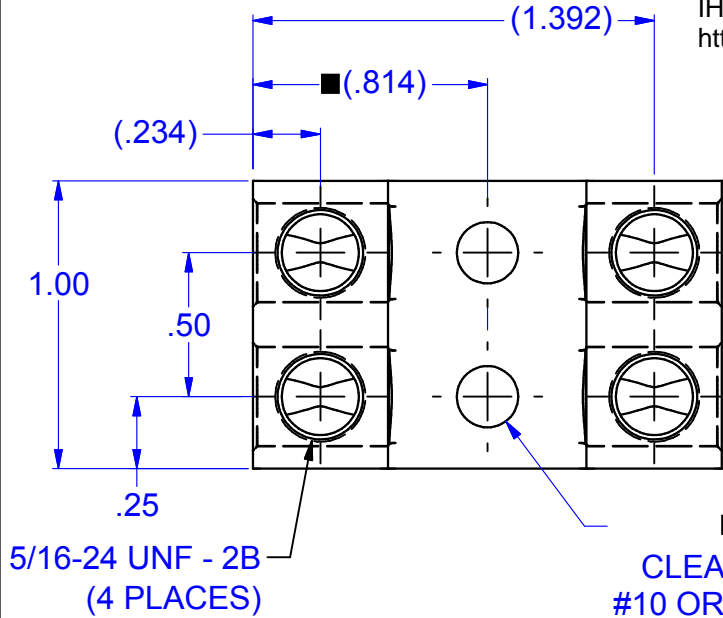

■  $\phi .21$   
 CLEARANCE FOR  
 #10 OR 5mm. SCREW

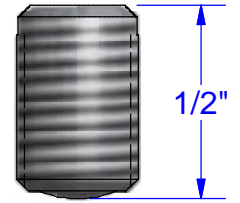
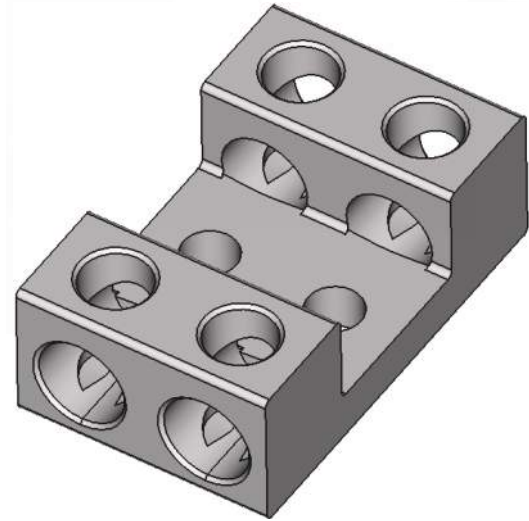
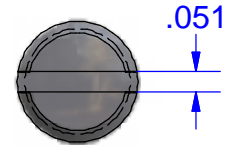

SCREW #10850  
 TIN PLATED  
 ALUMINUM

**MARKING**

S2  
 IHI  
 2-14  
 CU9AL  
 UL (LOGO)  
 CSA (LOGO)

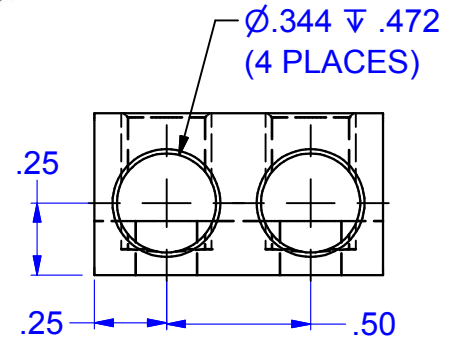
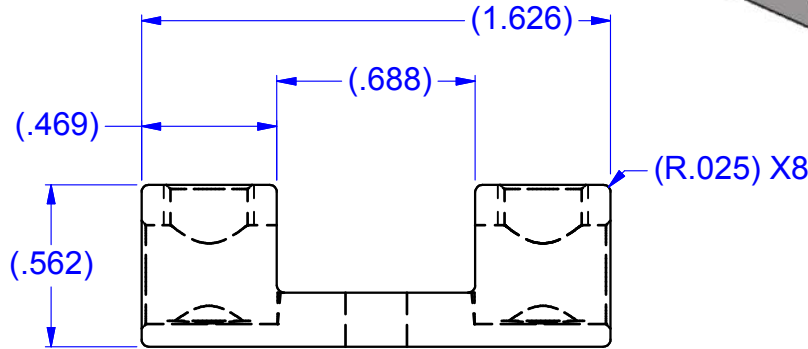

NOT FOR USE WHERE FAILURE CREATES A HAZARD TO HUMAN HEALTH OR SAFETY. ALL PRODUCTS ARE SUBJECT TO THIS FULL DISCLAIMER: <http://www.ihconnectors.com/disclaimer.html>

FOR FURTHER INFORMATION ON THE PROPER USE OF THIS PRODUCT IN SPECIFIC APPLICATIONS SEE <http://www.ihconnectors.com/GuideToFlexFlexibleFineStrandedWireCableMechanicalLugsFAQ.html> <http://www.ihconnectors.com/Technical-Data-Installation.htm>

Expanded wire range with use of ferrules.  
 TORK KRIMP, self crimping of standard UL Listed ferrules. Patent Pending.  
 For full instructions:  
<https://lugsdirect.com/PDF Documents/IHI Agency Labels/S2-AGENCY-LABEL.pdf>



THIS DRAWING AND DESIGN ARE THE PROPERTY OF INTERNATIONAL HYDRAULICS, INC., CLEVELAND, OHIO, AND MAY NOT BE DUPLICATED, USED FOR THE BASIS OF DESIGN OR MANUFACTURE WITHOUT THE WRITTEN PERMISSION OF INTERNATIONAL HYDRAULICS, INC., CLEVELAND, OHIO.		<b>INTERNATIONAL HYDRAULICS, INC.</b>		
<b>GENERAL TOLERANCES</b> $\pm .015 (\pm 0.038)$		TITLE: <b>S2-NB-2-10850 CONNECTOR</b>		
MATERIAL: <b>6061-T6</b>	SIZE: <b>1.5</b>	DRAWN BY: <b>TDS</b>	DWG NO.: <b>S2-NB-2-10850 (SALES)</b>	REV:
FINISH: <b>TIN PLATE EMS</b>	DATE: <b>6/2/11</b>	<b>IHI CONNECTORS</b>		